

TP04390A

ThermoStream® Thermal Airstream System



Mobile, Programmable Temperature System for high speed testing of components, parts, hybrids, modules, subassemblies and printed circuit boards at precise temperature.

TEMPERATURE PERFORMANCE AND AIRFLOW CAPACITY¹

Temperature Range ¹	-90° to +225°C (60 Hz Performance) -85° to +225°C (50 Hz Performance)
Typical Temperature Transition Rate (air)	-55° to +125°C: approximately 10 seconds or less ² +125° to -55°C: approximately 10 seconds or less ²
System Airflow Output	1.9 l/s to 8.5 l/s (4 to 18 scfm) CONTINUOUS
Temperature Accuracy	1.0°C (when calibrated against the NIST transfer standard)
Temperature Set, Display and Resolution	+/- 0.1°C

¹ Note: Ultimate low temperature and system performance may vary under operating conditions greater than or less than nominal.

Modes of Operation	Two: Operator Mode and Engineering Mode
Test Set-up Configurations	In Engineering Mode, an unlimited quantity may be created and saved to hard disk.
Ramp/Soak/Cycle Configurations	In Engineering Mode, up to 18 sequences per test set up. Table is displayed on screen.
Program and Data Storage	Datalogging and program files may be stored on the hard drive or USB storage device (i.e. USB memory stick, USB mass storage device or USB Printer)
Temperature Control:	
DUT Sensor Ports	Internal Diode, Type T and Type K thermocouple and 100 ohm platinum RTD.
DUT Control	Control to within +/-0.1°C, SELF-TUNING available in DUT Control
DUT Temperature Control	Proprietary Dual Loop Temperature Control - Unique control algorithm enables direct temperature control (to within 0.1°C) at the device case; measures temperature at the device.
User Definable Temperature Limits	Allows operator to select and set the upper and lower temperature limits within the -90° to +225°C system temperature range.
Heat Only Mode:	For reduced power consumption when cold temperatures are not required.
Remote Interface Ports	IEEE-488, RS232, Start Test/End Test/Stop on First Fail (ST/ET/SFF) and Ethernet.
Drivers	LabView® and LabWindows®
External Device Ports	Ports are located on the front of the system for connecting a mouse, printer and keyboard, in addition to a USB port.
On Screen HELP	Included for both Operator and Engineering Modes.
Status Indicators	On-screen and remote I/O
Purge Flow for Tester Interface	Dry purge to protect tester electronics from condensation, manually adjustable airflow from 0.25 to 1.5 liters per second (0.5 to 3 scfm)
Temperature Calibration	Automated, simplified and accurate for all temperatures and airflows
Thermal Head	Operation: Pneumatic control for raising and lowering of thermal head, operated manually or via remote interface. Positioner: Manual locking, 360° head rotation. Head can be manually pivoted, tilted, turned and vertically swung for ease of interface at the tester site.
Manipulator (arm) movement:	Motorized raising and lowering of arm; 330° positioning "swing" range around the base.

OPTIONS

Thermal Test Enclosures/ Chambers

Thermal Cap	Available in 2 sizes (4.5 in. and 5.5 in. ID). Choice of transparent glass or non-transparent metal (5.5 in. ID only). Enclosure attaches to Thermal Head to surround Device Under Test (DUT), providing a localized test environment at the test site.
ThermoChamber™	Compact, portable thermal enclosure attaches directly or via "Flexible Extender Hose" to ThermoStream for testing larger PCBs, assemblies and UUTs (Units Under Test). Allows convenient access for adding and removing UUTs. Available in three standard designs: Hood, Clamshell (top load) and Front Load. See ThermoChamber™ datasheets for specifications.

TP04390A

ThermoStream® Thermal Airstream System

Mobile, Programmable Temperature System for testing components, parts, hybrids, modules, subassemblies and printed circuit boards at precise temperature

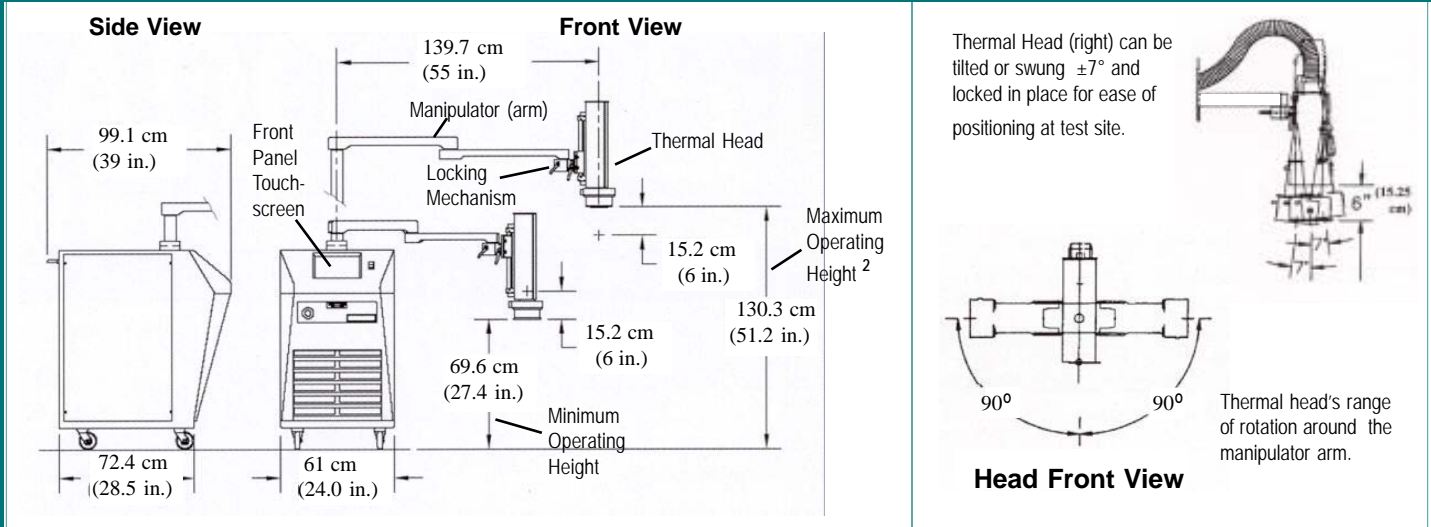

ENVIRONMENTAL AND SAFETY FEATURES

Over Temperature Protection	+230°C (factory set); (Also, operator can set high and low air temperature limits.)
Mobility	Four swivel caster wheels with locks ((10.16 cm (4 inch) diameter) static dissipative; rear handle for ease of transport
Refrigerants	HCFC and CFC-free, non-toxic, non-flammable
Serviceability	Auto-diagnostics and field replaceable modules
Maximum Operating Height ²	130.3 cm. (51.25 in.) approximately
Minimum Operating Height	69.6 cm. (27.4 in.) approximately
Noise level	<65 dBA

² Taller Operating Height is optional. Contact factory for details.

Weights and Dimensions

Base ³ :	Width: 61.0 cm. (24 in.), Depth: 72.4 cm. (28.5 in.), Height: 108 cm. (42.5 in.)
System Weight:	Not packed: 236 kg (520 lbs.); Packed: 365 kg (805 lbs.)

³ An additional 20.3 cm (8 in.) clearance is required for supply connections and cabinet ventilation.

FACILITY REQUIREMENTS⁴

Power Requirements ⁵	200-250 VAC (230 V nominal), 50/60 Hz, 30 amp, 1 phase
---------------------------------	---

Compressed Air Requirements

Clean, Dry Air:	Filtered to 5 micron particulate contamination. Oil Content: <0.01 ppm. by weight filtered to 0.01 micron oil contaminant. Dewpoint: <10°C @ 6.2 BAR (90 PSI)
-----------------	---

Supply Pressure	6.2 to 7.6 BAR (90 to 110 PSIG)
Supply Flow at Minimum Supply Pressure	7.2 to 14.3 l/s (15 to 30 scfm); 25 scfm nominal
Air Supply Temperature	+20° to +25°C ; +22°C nominal
Operating Temperature	+20° to +28°C; +23°C nominal
Humidity	0 to 60% ; 45% nominal

⁴ Under operating conditions which are greater or less than nominal, performance may be less than specification provided.

⁵ Note: System is configured for operation within voltages listed above using an internal transformer. Please specify power configuration with order.



ISO 9001-2000 Certified

©Copyright 2008, Temprotronic Corporation. These specifications are valid for the standard product and are subject to change without notice. Applications requiring modification to electrical, mechanical or thermal characteristics should be discussed with Temprotronic for possible accommodation at additional cost. ThermoStream® is a registered trademark of Temprotronic Corporation. Windows® is a registered trademark of Microsoft Corporation. Ethernet is a registered trademark of XEROX Corporation. LabView is a registered trademark of National Instruments Corporation. Printed in USA.



TEMPTRONIC
an INTEST Company

4 Commercial St.
Sharon, MA 02067 USA
Tel: 781-688-2300
FAX: 781-688-2301
www.temprotronic.com