

Operations Manual

CARRIER TO NOISE GENERATOR CNG

For firmware versions 3.31 and above



RF Test Equipment for Wireless Communications

Confidentially

This manual contains proprietary information of dBm, LLC. It is provided under confidential custody for the sole purpose of specification, installation, maintenance and operation of dBm test system instruments and equipment and may not be used or disclosed to any person for any other purpose whatsoever. No portion of this manual or the information it contains may be reproduced, used, or disclosed to individuals not having a need to know consistent with its intended purpose, without the written permission of dBm, LLC.

Copyright

This manual is copyright by dBm, LLC and all rights are reserved. No portion of this document may be reproduced, copied, transmitted, transcribed stored in a retrieval system, or translated in any form or by any means, electronic, mechanical, magnetic, optical, chemical, manual or otherwise, without written permission of dBm, LLC.

Disclaimer

dBm, LLC makes no representation or warranties with respect to the contents hereof and specifically disclaims any implied warranties of merchantability for any particular purpose.

dBm, LLC reserves the right to revise this publication and to make changes from time to time in the content thereof without obligation of dBm, LLC to notify any person of such revision or change.

© 2008 dBm, LLC. All rights reserved
All trademarks are the property of their respective holders
MAN2000000 Rev 1.72 01/08
Printed in U.S.A

TABLE OF CONTENTS

PREFACE	5
INTRODUCTION	9
GENERAL INFORMATION	10
FRONT PANEL VIEW	10
REAR PANEL CONNECTIONS	11
INSTRUMENT MODULES	12
START AND SHUTDOWN PROCEDURES	12
<i>Starting the CNG</i>	12
<i>Shutting Down the CNG</i>	13
LOCAL OPERATION	15
OPERATING STATES.....	15
<i>Power up and Preset</i>	15
<i>Ready State</i>	16
<i>Calibrating a Ratio</i>	16
<i>Run State</i>	16
<i>Tracking</i>	16
INSTRUMENT STATE KEYS.....	17
UTILITY KEYS	18
<i>To preset the instrument settings</i>	18
<i>To store the instrument settings</i>	18
<i>To recall a saved instrument setting</i>	18
<i>To return the instrument to local control</i>	18
<i>To set the IEEE-488 address</i>	19
DATA ENTRY KEYS	19
<i>Clear key</i>	19
PARAMETER KEYS.....	20
<i>Editing Parameters</i>	20
<i>Set C/N Eb/No, C/I or C/No Ratio</i>	21
<i>Set Output Power</i>	21
<i>Set bit rate or system bandwidth</i>	21
<i>Set number of power meter samples</i>	21
<i>Set sample rate of power meter</i>	22
<i>Set duty cycle of input signal</i>	22
<i>Modify RATIO while Running</i>	23
DISPLAYED PARAMETER FORMATS	24
<i>Ratio</i>	24
<i>Fc</i>	24
<i>BR or SBW</i>	24
<i>P_{in}</i>	24
<i>Duty cycle</i>	25
<i>P_{out}</i>	25
<i>Avg Fact</i>	25
<i>Avg Rate</i>	25
<i>•C</i>	25

REMOTE COMMANDS	26
COMMAND SYNTAX	26
<i>Terminator Codes</i>	26
<i>Concatenation Terminator</i>	27
<i>Spaces</i>	27
<i>Case Insensitivity</i>	27
GPIB TIMEOUT	27
GPIB COMMANDS	28
IEEE 488.2 STATUS REPORTING AND QUERIES	30
<i>Mandatory IEEE 488.2 Commands</i>	31
INSTALLATION AND TROUBLESHOOTING.....	40
INSTALLATION.....	41
<i>Unpacking the CNG</i>	41
<i>Initial Inspection</i>	41
<i>Applying power</i>	41
SYSTEM VERIFICATION	42
ERROR MESSAGES.....	43
OTHER DISPLAYED MESSAGES	44
LIMITATIONS OF MAXIMUM INPUT POWER VERSUS BIT RATE.....	45
LIMITATIONS OF MINIMUM NOISE DENSITY	46
DESCRIPTION AND SPECIFICATIONS	48
FUNCTIONAL DESCRIPTION	49
SPECIFICATIONS	50
MAINTENANCE AND WARRANTY	53
MAINTENANCE INFORMATION.....	54
<i>Adjustments and Calibration</i>	54
<i>Repair</i>	54
<i>Equipment Returns</i>	54
WARRANTY INFORMATION.....	55

Preface

This manual contains operation instructions and reference information for the dBm CNG. The CNG automatically combines AWGN with the user supplied signal.

This manual is prepared as a reference source for engineers and technicians to use the CNG as part of their Development and/or Production test effort

The CNG operations manual is divided into the following sections:

- **Section 1: Introduction** shows the CNG equipment, control and connector locations, and describes connector functions.
- **Section 2: Local Operation** describes how to operate the CNG from the front panel.
- **Section 3: Remote Operation** shows how to operate the CNG through the IEEE-488 connection.
- **Appendix A: Installation and Troubleshooting** describes installation procedures and lists error messages.
- **Appendix B: Description and Specifications** gives an overview of the CNG technical design and provides technical specifications, and verification testing .
- **Appendix C: Maintenance and Warranty** describes the CNG warranty and directs how to return the CNG for repair or calibration.

Conventions Used in This Manual

Text Conventions

This manual uses the following text conventions:

- *Italic text* indicates new terms, directories and/or filenames.
- **Bold Text** indicates CNG selections or key presses.
- Monospaced text indicates CNG commands entered through remote mode.
- **Bold monospaced text** indicates CNG responses through remote mode.

Symbols

The following symbols appear in the manual.

See also, 

This symbol and its “see also” text is placed next to subject matter in the manual to tell you where to find more information.



*This icon indicates a **warning**. Failure to follow the instructions given here may result in **personal injury** or **damage to the equipment**.*

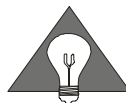

*This icon indicates a **tip**. Text marked this way may be an optional procedure for accomplishing a task, or a time-saving procedure for advanced or familiar users.*

Contacting dBm

We encourage you to contact us if you want more information or have any questions or concerns about this or any other dBm product or manual. Use any of the following methods:

Mail	dBm 32A Spruce Street Oakland, NJ 07436
Telephone	(201) 677-0008
Fax	(201) 677-9444
E-mail—Technical Support	<i>Info@dbmcorp.com</i>
www	<i>http://www.dbmcorp.com</i>



Introduction Section

Introduction

This section introduces you to the Carrier to Noise Generator instrument and describes the features and controls.

Topics include:

- Front, rear, and interior views.
- Power and cable connections.
- Startup and shutdown procedures.

GENERAL INFORMATION

Front panel view.

The Carrier to Noise Generator sets and maintains a highly accurate ratio between a user-supplied carrier and internally generated White Gaussian Noise. It also provides the ability to set an accurate ratio between the carrier and an externally supplied interference signal.

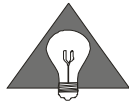

Figure 1. Instrument Front Panel View

Front views show two-channel model. Single-channel models are identical with the following exceptions:

Front: Has only one channel input and output.

For custom CNG units, consult additional documentation provided with the instrument.



Rear Panel Connections

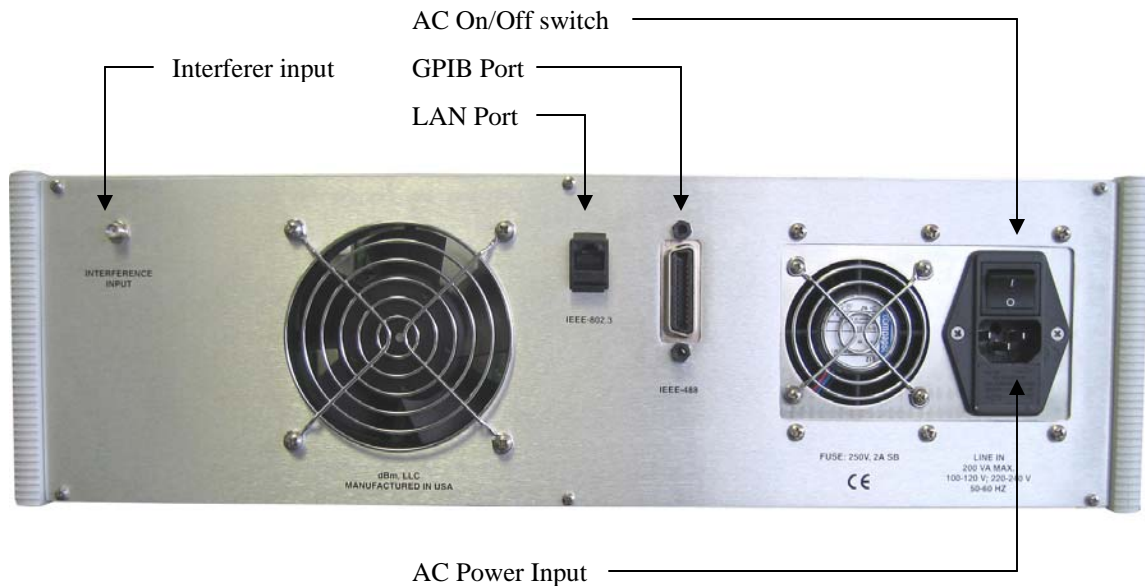
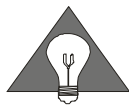

Figure 2. Instrument Rear Panel View (Single channel)

Rear view shows single-channel model. Dual-channel models are identical with the following exceptions:

Rear: Has two Interferer inputs.

For custom CNG units, consult additional documented provided with the instrument.



Instrument Modules

The CNG is constructed using modular self-contained sub-assembly trays. Each sub-assembly tray contains all its own necessary calibration data stored on flash memory, allowing individual modules to be easily changed in the field.

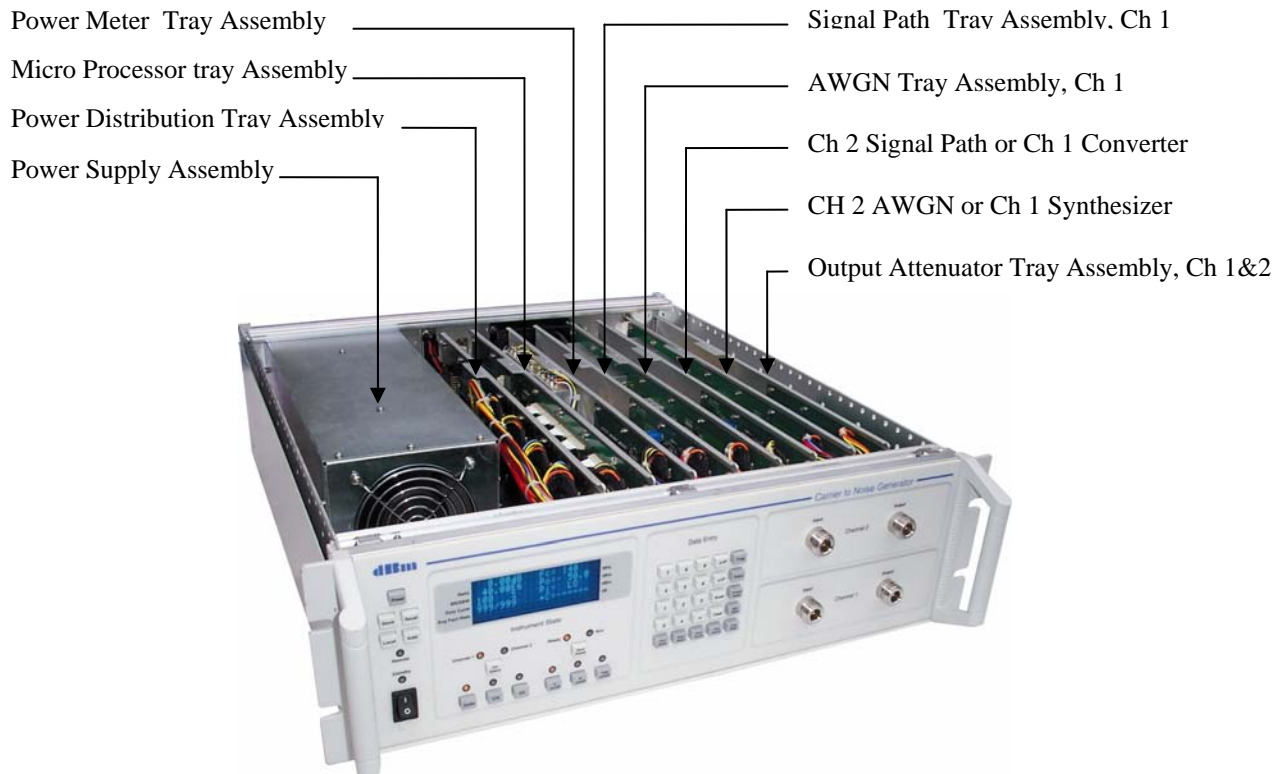

Figure 3. Interior view of 2 channel CNG

Start and Shutdown Procedures

Starting the CNG

1. Press the Line on/off switch on the rear panel. The standby indicator should light. If not lighted make sure the power cable is connected properly. Press the power on switch on the front panel. The standby LED turns off and the instrument powers on.
2. Allow power to be applied 30 minutes before using, so that the internal ovens may stabilize.

Shutting Down the CNG

1. Press the standby/on switch to standby. The standby LED illuminates.

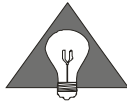

If the CNG is going to be off for an extended period of time, you may wish to remove the main power by pressing the Line on/off switch on the rear of the instrument.

2

Local Operation Section

Local Operation

The CNG is a laboratory instrument designed to precisely set the carrier to noise ratio by adding AWGN to the user supplied signal. The instrument may be controlled from the front panel or remotely via IEEE-488.

The resting state of the instrument is the **READY** state. The input signal power is monitored and displayed, and the signal passes through the instrument, un-attenuated and undisturbed.

After the user selects the appropriate settings, the user should press the **RUN/READY** button, commanding the instrument to transition from the **READY** state to the **RUN** state. The transition involves a calibration sequence which first measures the incoming signal power, then measures the internal noise source power, and then sets the power ratio between them via hardware attenuation, resulting in the output signal combined with noise at the desired ratio, and the output signal at the desired power level.

Operating States

Power up and Preset

Upon power-up or reset, the instrument is set to a predetermined state. The display will momentarily (3-5 sec) indicate the model number and the version of the installed firmware.

Ready State

The AWGN is disabled and the signal passes through the instrument un-attenuated. The internal power meter continuously measures and displays the input signal power. Parameters may be edited, saved, and recalled.

Calibrating a Ratio

Calibration is a temporary transition from the READY state to the RUN state. Calibration is initiated by the **RUN/READY** button. During calibration, the following sequence of events occur:

- The input signal power is measured.
- The desired signal output power is set.
- The noise is measured and set to give the final desired output ratio.

The combined signal and noise appear at the instrument output. The instrument monitors and displays the input power. The instrument also displays the carrier delta, that is the difference between in the real time measured input signal power relative to the 1st measurement of the signal power that was made immediately after calibration was completed.

Run State

At the successful completion of a ratio calibration, the instrument has measured the signal and the noise and has set the desired C/N (or Eb/No or C/No or C/I) ratio. The ratio can be modified in real time by either pressing the **Incr Ratio** or **Decr Ratio** buttons or pressing **Ratio** and typing in a new value. If the **Incr Ratio** or **Decr Ratio** buttons are pressed, the displayed value for **Ratio** is updated accordingly. The instrument remains in this state until the **Run/Ready** or **Preset** button is pressed.

Tracking

With tracking enabled, variations of input power, as sensed by the internal power meter, are negated by automatically changing the signal path gain. The range of tracking is +/- 5 dB with 0.008 dB resolution.

Instrument State Keys

Eb/No	Press <u>Eb/No</u> to set this mode. Can be modified in Ready state only. The Eb/No LED is lit only in this state.
C/N	Press <u>C/N</u> to set this mode. Can be modified in Ready state only. The C/N LED is lit only in this state.
C/I	Press <u>C/I</u> to set this mode. Can be modified in Ready state only. The C/I LED is lit only in this state.
TRK on/off	Press <u>TRK</u> to toggle tracking on and off. Can be modified in Run or Ready state. TRK on/off LED is lit only when TRK is enabled. When TRK is disabled, the signal path gain returns to its default setting.
C on/off	Press <u>C on/off</u> to toggle the output signal on and off. The output is always on when first entering Run state, but can be toggled off while in the Run state. In the Ready state, the output is on. The C on/off LED is lit when the output signal path is on.
N on/off	Press <u>N on/off</u> to toggle the noise on and off. The noise is always on when first entering RUN state, but can be toggled off while in the Run state. In the Ready state, the noise output is off. The LED is lit when noise is on.
Channel	Press <u>Channel 1</u> or <u>Channel 2</u> to select the desired channel to be manipulated.. Can be modified when the instrument is in the Ready or Run state. Two LEDs are used to indicate which channel is active. Display and key entry functions relate to the active channel.
RUN/READY	Press <u>Run/Ready</u> to alternate between the Run and Ready state. Two LEDs are used to indicate the current state. The READY LED illuminates in the READY state. The RUN LED illuminates in the RUN state. Both LED's are off during the ratio calibration process.

Utility Keys

To preset the instrument settings

- Pressing **Preset** causes the instrument to return to the default state. Preset does not affect the IEEE488 address

To store the instrument settings

- Press **Store**. The utility display appears and the pointer is adjacent to the STORE field.
- Press a number from 0-9, designating a register to store the current instrument settings. The parameters that are saved are the values in the main display and all of the instrument state buttons. The IEEE address is not part of this storage register and is saved separately.
- Press **Enter** to overwrite the register, or **Clear** to abort.

To recall a saved instrument setting

- Press **Recall**. The utility display appears and the pointer appears adjacent to the Recall field.
- Press a number from 0-9, designating a register to recall instrument settings.
- Press **Enter** to recall the instrument state, or **Clear** to abort.

To return the instrument to local control

During remote operation, all keys except **Local** are inactive. **Local** brings the instrument back to the local mode and activates the front panel keys.

- Press **Local**

To set the IEEE-488 address

- Press **Addr**. The utility menu appears. Press **1** to invoke the GPIB address menu.
- Press a number from 1 to 31, designating the IEEE address.
- Press **Enter** to enter the new address, or press **Clear** to abort.

To set the LAN address

- Press **Addr**. The utility menu appears. Press **2** to invoke the LAN address menu.
-
- Press **1** and then enter the IP address. Press **Enter** when finished, or **Clear** to return without modifying the value.
-
- Press **2** and then enter the submask. Press **Enter** when finished, or **Clear** to return without modifying the value.
- Press **Enter** to return to the main display.

Data Entry Keys

This section describes how the Data Entry Keys are used:

When a parameter key is pressed (for example **Freq**), a pointer appears adjacent to the corresponding field. The presence of the pointer indicates that the field can be edited. Note that the pointer can be visible at any one, but only one, of six locations.

The user enters the new value via the keypad. After the **Enter** key has been pressed, the new value is stored and the pointer disappears. Anytime the pointer is adjacent to a field, that field may be edited. If a different parameter key is depressed while the pointer is present, the pointer immediately moves to the appropriate field.

Clear key

The **Clear** key can be used to delete an inadvertent numeric value prior to pressing the **Enter** key.

Example

- Press **Freq** to select the frequency field. The pointer appears at the frequency field.

- Type a new value for the desired frequency.
- Press **Enter**. The new value is entered and the pointer disappears.
- Press **Freq** to select the frequency field. The pointer appears at the frequency field.
- Type a new value via the keypad. The numeric values appear as the new value is typed.
- Press **Clear**. The previously programmed frequency value appears, and the pointer remains visible.
- Press **Duty Cycle**. The pointer moves to the Duty Cycle field.
- Press **Clear again**. The pointer is removed and no display value can be edited.

Change the sign of a value

- Press “-“ while editing a parameter to change the sign of the entered value.

Parameter Keys

Editing Parameters

- Press the desired parameter key (for example **Freq**).
- Press the desired numeric value then press **Enter** to change the current value and remove the pointer.

All keys are valid during the Ready state except **Decr Ratio**. The **Incr Ratio** key is used on Ready state only for modifying the ratio step size.

While in Run mode, the only front panel controls that are recognized are **Ratio**, **Incr Ratio**, **Decr Ratio**, **TRK on/off**, **C on/off**, **N on/off**, **Run/Ready**, and **Preset**

Set C/N Eb/No, C/I or C/No Ratio

- Press **Ratio** (valid during Ready and Run states).
- Press numeric value (valid range 0 to +/- 99.99).
- Press **Enter** to enter.

Set Output Power

Note: If the CNG was purchased with CNGopt02, no output attenuator is present, and therefore this paragraph should be ignored.

- Press Output Power (valid during Ready state only).
- Press numeric value (valid range +0.0 to -110.0, 0.1dB steps).
- Press **Enter** to enter and remove the pointer.

Some units may have custom input and output power levels. Please check to see if any specialized documentation is included with your unit indicating custom power levels.

Set bit rate or system bandwidth

- Press **BR/SBW** (valid during Ready state only).
- Press numeric value (valid range 0 to 200E6).
- Press **x10⁶** to multiply by 1E6, enter the value and remove the pointer or:
- Press **x10³** to multiply by 1E3, enter the value and remove the pointer or:
- Press **Enter** to enter and remove the pointer.

Set number of power meter samples

- Press **Avg Fact** (valid during Ready state only)
- Press numeric value (valid range 10 to 9999, 1 unit steps).
- Press **Enter** to enter and remove the pointer.

*Note: **Avg Fact** is the number of measurements that the internal power meter averages to calculate the measured power.*

Set sample rate of power meter

- Press **Avg Rate** (valid during Ready state only).
- Press numeric value (valid range 5 to 999 Hz, 1 Hz steps).
- Press **Enter** to enter and remove the pointer.

*Note: **Avg Rate** is the rate that the internal power meter takes consecutive power measurements.*

Set duty cycle of input signal

- Press **Duty Cycle** (valid during Ready state only).
- Press numeric value (valid range 1 to 100%, 1% steps).
- Press **Enter** to enter and remove the pointer.

*Note: **Duty Cycle** is used to compensate the power measurement for pulse modulated signals*

Set the Ratio Step Size

- Press and hold the **Incr Ratio** for 3 seconds. A menu will appear to allow setting the ratio step size. Valid values are 0.015625 dB up to 99.98 dB.
- Press **Enter** to accept the new value. Press Clear to return without modifying the value.
- The ratio step size can be modified in both the Run and Ready states.

Modify **RATIO** while Running

- Press **Incr Ratio** to increase the ratio by the ratio step size (valid during Run state only).
- Press **Decr Ratio** to reduce the ratio by the ratio step size (valid during Run state only).

Alternatively

- Press **Ratio**
- Press numeric value (valid range 0 to +/- 99.99).
- Press **Enter** to enter.

Entering a **RATIO** Offset

A fixed offset value can be applied to the displayed Ratio. For example, if the displayed ratio is 10 dB, and the offset value is -0.5 dB, the actual calibrated ratio will be 9.5 dB.

- In either Run or Ready mode, press and hold the **RATIO** key for 3 seconds.
- A menu will appear to allow setting a ratio offset value. Valid values are +/- 0.015625 to 99.98 dB
- Press **Enter** to accept the new value, or **Clear** to return using the original value.

Displayed Parameter Formats

There are 9 parameter fields visible on the main display page.

Ratio The type of ratio is selected by one of the C/N, Eb/No, or C/I keys.

Units: dB
Default value: 0
Range: 00.0 to +/- 99.99 dB
Resolution 0.01 dB

Fc The current value for center frequency.
Units: MHz
Default value: the lowest valid frequency
Resolution: 1 MHz

BR or SBW The current value for bit rate (Eb/No mode) or signal bandwidth (C/N or C/No mode)

Units: BPS or Hz
Default: 40E6
Range: 0 to 200e6, Note: SBW = 0 will place the instrument in C/No mode
Resolution 2 decimal places

P_{in} The measured value of the input power.

Units: dBm
Range: -50.0 to +0.0 dBm
Resolution 0.1 dB

Duty cycle The user supplied value used by the internal power meter to compensate for pulse modulated signals..

Units: Percent
 Default: 100%
 Range: 1 to 100%
 Resolution 1%

P_{out} the current value for output power.

Units: dBm
 Range: -55.0 to +0.0 dBm. (-110 dBm to 0 dBm, -50dBm to 0dBm with CNGopt02)
 Resolution: 0.1 dB

Avg Fact The number of measurements that the internal power meter averages to calculate the measured power.

Units none
 Range 10 to 9999
 Resolution 1

Avg Rate The rate that the internal power meter takes consecutive power measurements.

Units Hz
 Range 5 to 999 Hz
 Resolution 1 Hz

♦C The real time input power relative to the initial value taken when 1st entering the RUN mode

Units dB
 Range 0 to +/- 6 dB (displays “---“ while in Ready mode, displays ‘Error” if input power changes more then 6dB after a calibration is completed)
 Resolution 0.1 dB

3

Remote Operation Section

Remote Commands

All CNG commands are compliant with IEEE-488.2. The instrument can function as a talker or a listener, but not as a controller.

The instrument switches to remote mode upon receipt of the remote command (REN) and the correct address.

The instrument switches to local mode upon pressing the **Local** key or upon power-up. To return to local operation, press and hold the **Local** key until the REMOTE LED is no longer illuminated.

Command Syntax

Terminator Codes

When sending data to the CNG, any of the following terminator codes are valid:

- Send EOI at end of Write
- Terminate read on EOS
- Set EOI w/EOS on Write
- 8-bit EOS (compare)

Concatenation Terminator

Multiple commands on a single line are separated by the semi-colon concatenation terminator ";".

Example: CH1; RUN

Spaces

The ASCII space character may appear after any command, or after the concatenation terminator.

Case Insensitivity

Commands and queries may be sent in upper and/or lower case characters.

GPIB Timeout

If the response to any query exceeds the GPIB timeout of the host controller, a timeout error will occur. To avoid timeout errors, the programmer can insert a delay prior to a query. The RUN command, for example, takes longer to complete than most commands. For the case of a RUN command followed by a *OPC query, the programmer can do the following:

Replace

```
CH1;RUN;*OPC?
```

with

```
CH1;RUN  
<insert delay here>  
*OPC?
```

The CNG timeout can be changed by pressing LOCAL, then select Timeout, and then select the desired value ranging from 0 (timeout disabled) to 134 seconds.

GPIB Commands

When addressed to listen, the CNG responds to the following commands:

Function	Listener Codes
Channel number	CHX, x is channel 1 or 2
Set ratio step size	RSTEP
Increment Ratio	INCR
Decrement Ratio	DECR
Carrier ON	CON
Carrier OFF	COFF
Noise ON	NON
Noise OFF	NOFF
Run	RUN
Ready	RDY
Eb/No	EBNO
C/N	CN
C/I	CI
Track ON	TRKON
Track OFF	TRKOFF
Ratio	RATIO +/- XX.X
Frequency	FREQ XXXX
Bit rate	BR X.XXEX
Signal Bandwidth	SBW X.XXEX
Output Power	OUTP +/-XXX.X
Duty Cycle	DUTY XXX
Average Factor	FACT XXX
Average Rate	RATE XXX
Store	*SAVx (x is 0 to 9)
Recall	*RCLx (x is 0 to 9)
GPIB address	ADDR XX
LAN address	LAN_ADDR XXX.XXX.XXX.XXX
Identification Query	*IDN?
Reset Command	*RST
Self-Test Query (return "0" on success)	* TST?
Operation Complete Command	*OPC

Operation Complete Query	*OPC?
Wait-to-Continue	*WAI
Clear Status	*CLS
Event Status Enable	*ESE
Event Status Enable Query	*ESE?
Event Status Register Query	*ESR?
Service Request Enable Command	*SRE
Service Request Enable Query	*SRE?
Read Status Byte	*STB?

Figure 4. GPIB Commands

Query command	Response	Default units
CH?	1 or 2	None
RATIO?	Programmed value	dB
BR?	Programmed value	Hz
SBW?	Programmed value	Hz
FREQ?	Programmed value	MHz
OUTP?	Measurement value	dBm
INP?	Measurement value	dBm
DELTAC?	Measurement value	dB
DUTY?	Programmed value	%
FACT?	Programmed value	none
RATE?	Programmed value	Hz
MODE?	String CN, EBNO, CI	none
STATE?	String RUN, RDY, CALIBRATE	none
CON?	Boolean 0 or 1, where 1 indicates on	none
NON?	Boolean 0 or 1, where 1 indicates on	none
TRKON?	Boolean 0 or 1, where 1 indicates on	none
RSTEP?	Programmed value	dB

Figure 5. GPIB Query Commands

Notes:

- Mandatory IEEE 488.2 commands begin with an '*'. Details about these commands can be found in IEEE Std 488.2.
- X represents numeric values from 0 to 9.
- The above commands, except CHX, and commands beginning with a '*' must be preceded by CHX to indicate which channel is applicable. Once the channel has been designated, all subsequent commands will relate to that channel. The CHX command is not necessary for single channel instruments.
- Spaces within the command are ignored.

IEEE 488.2 Status Reporting and Queries

The CNG supports IEEE-488.2 status reporting. Status is reported using an 8 bit Status Byte and an 8 bit Standard Event Status Register.

Status Register Bit Assignments

<i>Bit #</i>	<i>Description</i>
0	not used
1	not used
2	not used
3	not used
4	MAV
5	ESB
6	MSS
7	not used

Event Status Register Bit Assignments

<i>Bit #</i>	<i>Description</i>
0	Operation Complete
1	Request Control
2	Query Error
3	Device Dependent Error
4	Execution Error
5	Command Error

6
7User Request
Power On

The Device Dependent Error bit is set when the signal or noise is out of range. The Command Error bit is set when an unknown command or query is received.

Mandatory IEEE 488.2 Commands

*RST - Reset Command

The Reset command performs a CNG reset. It does not affect the state of the IEEE 488 interface, nor any Event Enable Register setting including the Standard Event Status Enable Register settings.

*RCL

The recall function is used to configure the CNG in one of ten user-defined states. The recall registers are labeled 0 – 9. Registers for which the user has not written to will contain default settings. The recall function does not disturb the state of the IEEE-488 interface or any Event Enable Register settings.

*SAV

The save function is used to store the current CNG configuration in one of ten user-defined states. The save registers are labeled 0 – 9.

*IDN - Identification Query

The Identification query allows the CNG to identify itself over the system interface. The response is composed of four fields:

- Field 1 Manufacturer
- Field 2 Model
- Field 3 Serial number (not used)
- Field 4 Firmware level

Manufacturer: dBm LLC

Model: CNG-<number of channels>-<low frequency>/<high frequency> Ex.: CNG-2-50/180

Serial number: ASCII character "0", zero

Firmware level: Version number

An example response to the *IDN? query is:

```
"dBm LLC,CNG-1-70/140,0,1.18"
```

***TST? - Self-Test Query**

The self-test query causes the ASCII character "0" (zero) to be placed in the Output Queue upon successful completion of a self-test.

***OPC - Operation Complete Command**

The Operation Complete command causes the CNG to set the Operation Complete bit of the Standard Event Status Register when all operations are finished.

***OPC? - Operation Complete Query**

The Operation Complete query places an ASCII character "1" (one) into the CNG's Output Queue when all operations are finished.

***WAI - Wait-to-Continue Command**

The Wait-to-Continue command has no functional affect on the CNG since the CNG implements all commands sequentially. No commands are overlapped, that is, one command must finish before the next command is executed.

***CLS - Clear Status Command**

The Clear Status command clears status data structures. The Clear Status command clears all bits in the Standard Event Status Register and its summary ESB bit in the Status Register. It does not necessarily clear all bits in the Status Byte Register. For example, the MAV bit may not be cleared by the *CLS command.

***ESE - Standard Event Status Enable Command**

The Standard Event Status Enable command sets the Standard Event Status Enable (ESE) Register bits. The ESE is involved in the setting and clearing of the Event Summary Bit (ESB) of the Status Byte Register. The ESB is the inclusive OR of the bitwise combination of the Standard Event Status Register (ESR) and the ESE Register.

ESB is defined as

(ESR bit 0 AND ESE Register bit 0)
 OR
 (ESR bit 1 AND ESE Register bit 1)
 OR
 (ESR bit 2 AND ESE Register bit 2)
 OR
 (ESR bit 3 AND ESE Register bit 3)
 OR
 (ESR bit 4 AND ESE Register bit 4)
 OR
 (ESR bit 5 AND ESE Register bit 5)
 OR
 (ESR bit 6 AND ESE Register bit 6)
 OR
 (ESR bit 7 AND ESE Register bit 7)

***ESE? - Standard Event Status Enable Query**

The Standard Event Status Enable query lets the programmer determine the contents of the Standard Event Status Enable Register.

***ESR? - Standard Event Status Register Query**

The Standard Event Status Register query lets the programmer determine the contents of the Standard Event Status Register. The Standard Event Status Register is destructively read, that is, it is read and cleared with the *ESR? query.

Event Status Register Bit Assignments

Bit #	Description
0	Operation Complete
1	(Request Control)
2	(Query Error)
3	Device Dependent Error
4	(Execution Error)
5	Command Error
6	(User Request)
7	(Power On)

Bit assignments in parentheses are bits that have been assigned by the IEEE 488.2 standard but may not be currently used by the CNG.

Operation Complete Bit - set upon execution of the *OPC command.

Device Dependent Error Bit - set when any of the following errors occur:

- Input Power too high
- Input Power too low
- Output Power too high
- Output Power too low
- Noise Power out of range
- Interferer Power out of range

Command Error Bit - set whenever an unknown command or query is received.

***SRE - Service Request Enable Command**

The Service Request Enable command sets the Service Request Enable (SRE) Register bits. The SRE is involved in the setting and clearing of the Master Summary Status (MSS) bit of the Status Byte Register. The MSS bit indicates that the CNG has at least one reason for requesting service. The MSS bit of the Status Byte Register is the inclusive OR of the bitwise combination (excluding bit 6) of the Status Byte (SB) Register and the SRE Register.

MSS is defined as

(SB Register bit 0 AND SRE Register bit 0)
OR
(SB Register bit 1 AND SRE Register bit 1)
OR
(SB Register bit 2 AND SRE Register bit 2)
OR
(SB Register bit 3 AND SRE Register bit 3)
OR
(SB Register bit 4 AND SRE Register bit 4)
OR
(SB Register bit 5 AND SRE Register bit 5)
OR
(SB Register bit 7 AND SRE Register bit 7)

***SRE? - Service Request Enable Query**

The Standard Event Status Enable query lets the programmer determine the contents of the Service Request Enable Register. This register is set to 16 (decimal) at power-on.

*STB? - Read Status Byte Query

The Read Status Byte query lets the programmer read the status byte.

Bit #	Description
0	-
1	-
2	-
3	-
4	MAV
5	ESB
6	MSS
7	-

Status Byte Register Bit Assignments

LAN Operation Overview

The CNG can be controlled remotely using its LAN interface. The instrument can be connected to any IEEE-802 network. It uses TCP/IP, and achieves transfer rates up to approximately 5 Mbps.

Programming control of the CNG can be implemented by two means: 1) Using the CNG Client Application provided by dBm with the instrument or 2) by creating an application to send the commands over IP.

The CNG Client Application provides a simple user interface to control the CNG.

Installing the CNG Remote Client on a PC

The CNG Client Application can be copied from the provided CD to a directory on a PC. Create a directory, for example c:\CNG Client, and copy the following file into the directory:

CNGControl.exe

Connecting to the CNG

To establish a connection from the PC to the CNG, connect the two devices to a local area network, or connect them directly using an ethernet *crossover* cable.

Commands

The CNG LAN interface responds to the following ASCII commands and queries, which mimic the GPIB commands:

Function	Codes
Channel number	CHX, x is channel 1 or 2
Set ratio step size	RSTEP
Increment Ratio	INCR
Decrement Ratio	DECR
Carrier ON	CON
Carrier OFF	COFF
Noise ON	NON
Noise OFF	NOFF
Run	RUN
Ready	RDY
Eb/No	EBNO
C/N	CN
C/I	CI
Track ON	TRKON
Track OFF	TRKOFF
Ratio	RATIO +/- XX.X
Frequency	FREQ XXXX
Bit rate	BR X.XXEX
Signal Bandwidth	SBW X.XXEX
Output Power	OUTP +/-XXX.X
Duty Cycle	DUTY XXX
Average Factor	FACT XXX
Average Rate	RATE XXX
Store	*SAVx (x is 0 to 8)
Recall	*RCLx (x is 0 to 9)
Identification Query	*IDN?
Reset Command	*RST

Figure 6. LAN Commands

Query command	Response	Default units
CH?	1 or 2	None
RATIO?	Programmed value	dB
BR?	Programmed value	Hz
SBW?	Programmed value	Hz
FREQ?	Programmed value	MHz
OUTP?	Measurement value	dBm
INP?	Measurement value	dBm
DELTAC?	Measurement value	dB
DUTY?	Programmed value	%
FACT?	Programmed value	none
RATE?	Programmed value	Hz
MODE?	String CN, EBNO, CI	none
STATE?	String RUN, RDY, CALIBRATE	none
CON?	Boolean 0 or 1, where 1 indicates on	none
NON?	Boolean 0 or 1, where 1 indicates on	none
TRKON?	Boolean 0 or 1, where 1 indicates on	none
RSTEP?	Programmed value	dB

Figure 7. LAN Query Commands

Description of the CNG Remote Client

The CNG Client provides a graphical interface to control the CNG from a PC via a LAN connection. The client application provides status and control of all installed channels. The client can address multiple CNG instruments by changing the IP address in the control window.

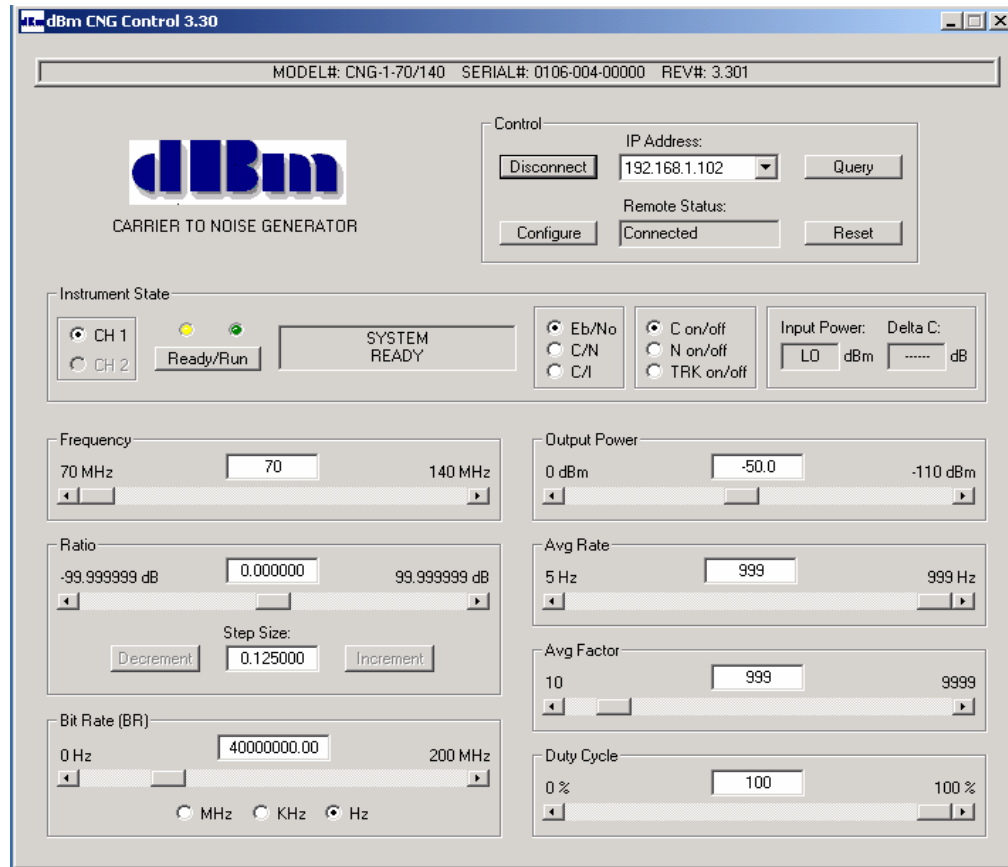

CNG Control Window

Configure the Client

Select the Configure button to invoke the Configure window. In the Client configure window, enter the IP address(es) to match the CNG IP address(es). The factory default CNG address is 192.168.1.104.

In the Client main window, set the IP address to match the CNG IP address. Press "Connect". When the link is established, the same button will indicate "Disconnect" and the status window labeled *Remote Status* will also indicate "Connected". The client will poll the CNG once the connection is established and display the model number, serial number, and firmware version at the top of the window. The Query button forces the same function to occur.

Instrument settings can be stored and recalled. Each CNG channel has eight possible configurations that can be stored. The values at location zero are used at power-up and reset. The values at location nine cannot be modified, and are the factory default values.

Controlling the CNG with the Client

Upon startup, the client will indicate the current parameters for the selected channel. Press the "CH2" button to view the parameters for the 2nd channel (if installed). A parameter can be modified by overwriting the existing value in the text box and then moving the cursor to another field, or by moving the slider bar, or by clicking the end points on a slider.

To simplify entry of the Bit Rate when using the slider bar, the resolution of the slider end points is controlled by the buttons labeled "MHz", "kHz", and "Hz". Selecting one of these buttons causes the end points to change the current value by that amount. For example, if "kHz" is selected, then each click will change the Bit Rate value by 1 kHz.

The Input Power and Delta C are continuously read from the CNG and displayed on the GUI.

Press "Ready/Run" to toggle between the two states. Any encountered error conditions are displayed in the box to the left of the "Ready/Run" button.

Press the "Disconnect" button to allow the CNG to be put back into the local mode. If the LAN connection remains connected, the CNG cannot be put into local mode by the instrument's front panel button labeled "Local" .



Installation and Troubleshooting

Installation and troubleshooting

If your CNG unit does not appear to be performing as expected, verification tests can determine whether the unit is functioning properly.

This section describes installation instructions, CNG verification tests and provides a checklist for results.

Topic includes:

- System Installation
- Error messages

Installation

Unpacking the CNG

Remove the CNG materials from the shipping containers. Save the containers for future use.

The standard CNG shipment includes:

Quantity	Description
1	Carrier to Noise Generator
1	AC power cord
1	CNG User Manual

Initial Inspection

Inspect the shipping container (s) for damage. If container is damaged, retain it until contents of the shipment have been verified against the packing list and instruments have been inspected for mechanical and electrical operation.

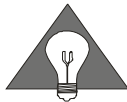

If the CNG appears to have been damaged during shipping, do not install the unit. Contact dBm immediately.

Applying power

1. Place the CNG on the intended workbench and connect the AC power cord to the receptacle on the rear of the unit.
2. Press the Line on/off switch on the rear panel. The standby indicator should illuminate
3. Press the power on switch on the front panel. The standby LED should turn off and the instrument should power on.

System verification

The following section provides the procedure to verify correct operation of the CNG.

1. Attach a main AC power cord and set the rear panel main power switch to the up position. The front panel standby LED will illuminate.
2. Turn on the front panel power switch. The model number and software version will appear in the display, followed by the Instrument State display.

Note: Power must be applied to the CNG for 30 minutes for full accuracy.

3. Apply a CW RF signal with a power level of -1.0 dBm to the CNG input. The frequency of CW RF signal may be set anywhere between the minimum and maximum limits of the CNG
4. Press the **Freq** button. Type the frequency (in MHz) for the CW RF signal used in step 3, and then press **Enter**.
5. The displayed input power, P_{in} , should be approximately -1 dBm.

Note: The displayed power accuracy is typically ± 0.1 dB.

6. Connect a spectrum analyzer to the CNG output, and measure the signal power. It should be approximately -1 dBm.

Note: The CNG signal path gain is typically 0 dB ± 0.05 dB.

7. Enter the following settings on the CNG:
 - Ratio = 23 dB (Press **Ratio**, then 23, then **Enter**)
 - BR = 1E6 (Press **BR**, then 1, then **E6**)
 - Output Power = -1.3 dBm (Press **Output Power**, then -1.3 then **Enter**)
 - All other controls remain at their default values.
8. Press the **Run/Ready** key.
9. The display will indicate "SYSTEM CALIBRATING".
10. When calibration is complete, the green "Run" LED will illuminate, and the CNG output will be enabled with the signal and the additive noise. The noise spectrum will cover the entire CNG

operating range, and the noise density will be approximately -84.2 dBm/Hz at the frequency of the CW RF signal..

11. Note: The Eb/No, C/N, C/No or C/I ratio accuracy set by the CNG is typically better than ± 0.05 dB, but specialized equipment is required to make a this measurement with sufficient accuracy.
12. Press the **Run/Ready** key to return to the Ready state.

Error messages

Certain conditions will prevent the instrument from setting a ratio with the desired parameter values. If calibration cannot be achieved (after the user invokes the RUN state), one of the following error messages is displayed in place of the main display. The message is reset when the **Run/Ready** key is pressed.

Input Power Too High

occurs if during a calibration, the measured input signal power is > 0 dBm. Correct the problem by reducing the input signal power.

Input Power Too Low

occurs if during a calibration, the measured input signal power is < -50 dBm. Correct the problem by raising the input power.

Output Power Too Low

occurs when the difference between the measured input signal power and the desired output signal power is greater than 60 dB (beyond attenuator range). Correct the problem by reducing the input signal power or increase the output power setting.

Output Power Too High

occurs when the output signal power setting is higher than the actual input signal power. Correct by increasing the input signal power or by setting the output power to less than the measured input signal power.

Noise Power Out of Range

occurs when a calibration requires the total noise power to be outside the range of 0 dBm to -60 dBm. Refer to the *Limitations on maximum noise density section* to determine how to modify the settings to successfully achieve a calibration. Typically, the problem can be corrected by changing the input signal power.

Interferer Power Out of Range

Occurs when the desired interferer power is outside the range of allowable range of the instrument. Verify that the injected interferer signal power is near -5 dBm.

Other Displayed messages

Certain conditions will cause the instrument to replace one or more parameter fields with a message.

TRK	Replaces the input power value when tracking is enabled.
HI	Replaces the input power value when the input signal level is greater than 0 dBm.
LO	Replaces the input power value when the input signal level is less than the minimum operating power.
OFF	Replaces the output power value when the carrier signal is disabled
----	replaces the ratio value when the AWGN is disabled
----	replaces the BR value when in C/I mode
ERROR	replaces the \bullet C value when the measured input power has changed more than 6 dB after a ratio calibration was performed. If tracking is enabled,

replace the $\star C$ value when the measured input power has changed more than 12dB, exceeding the tracking range.

Limitations of Maximum Input Power versus Bit Rate

The CNG generates Additive White Gaussian Noise (AWGN) which covers the total operating range of the instrument. When the bit rate (or bandwidth) of the input signal is small, only a small portion of the total noise power is utilized. Since noise power is directly proportional to bandwidth, the larger the ratio of the CNG's total noise bandwidth relative to the applied signal bandwidth, the less the usable dynamic range of the instrument. Therefore, for signals occupying a small bandwidth, the maximum power level of the noise in that bandwidth is small, even though the total AWGN power is 0 dBm.

The maximum input signal power can be expressed as a function of the occupied bandwidth and the desired C/N ratio.

Mathematically, the limit is expressed as:

$$P_{\max} = -10 \cdot \text{LOG}(200\text{E}6/\text{BR}) + C/N$$

Bit Rate	Input Signal Power Range
10 kHz	-43 dBm to -50 dBm
1 MHz	-23 dBm to -50 dBm
10 MHz	-13 dBm to -50 dBm
99 MHz	-3 dBm to -50 dBm

Figure 5 Examples of Maximum Input Power Limits for C/N = 0 dB

Limitations of Minimum Noise Density

The CNG is capable of generating noise densities over a 60 dB range, from approximately -83 dBm/Hz to -143 dBm/Hz. However, the residual noise floor at the output of the instrument is approximately -149 dBm/Hz. The total output noise density will be the sum of these two components. As the AWGN density approaches the residual noise, the error in the total noise density increases. For example, if the AWGN density is 10 dB above the residual noise, the total noise power will be 0.458 dB higher than desired, resulting in an error in desired C/N ratio.

The recommended operating range of the AWGN power density is greater than -129 dBm/Hz (C/N error = 0.04 dB). This limitation in the minimum noise density will only occur for extremely wide occupied signal bandwidths or for very large C/N ratios. The limitation can be described mathematically:

$$N_{\min} = -127 \text{ dBm} = -10 \cdot \log(BR) + P_{\text{in}} - C/N$$

BR	P_{in}	C/N	Noise Density
10kHz	-50	37	-127
99MHz	-47	0	-127

Figure 6. Examples of Minimum Noise Density Limits

B

Description and Specifications Section

Description and Specifications

This section describes the CNG technical details and specifications.
Topics include:

- Functional description of the instrument
- Instrument setting limitations
- Specifications

Functional Description

A dual range power meter is used to measure the signal power and the noise power. The meter has a 25 dB dynamic range, with the two solid state range selectors extending it to 50 dB. The range selection occurs automatically as a function of actual input power.

The meter is shared between two channels so the channels cannot be calibrated simultaneously.

The meter can measure the input signal power or the noise source power.

The output attenuator is used to set the output signal power. It has 60 dB range with 1 dB steps.

The noise attenuator is used to set the noise power and the interferer power relative to the signal power. It has 60 dB range with 0.015625 dB steps.

The tracking function cancels any variations of the input signal power, so that the output signal power remains constant. It is part of a closed loop gain control, in which the processor reads the power meter, and feeds back to the tracking module in order to maintain a constant power.

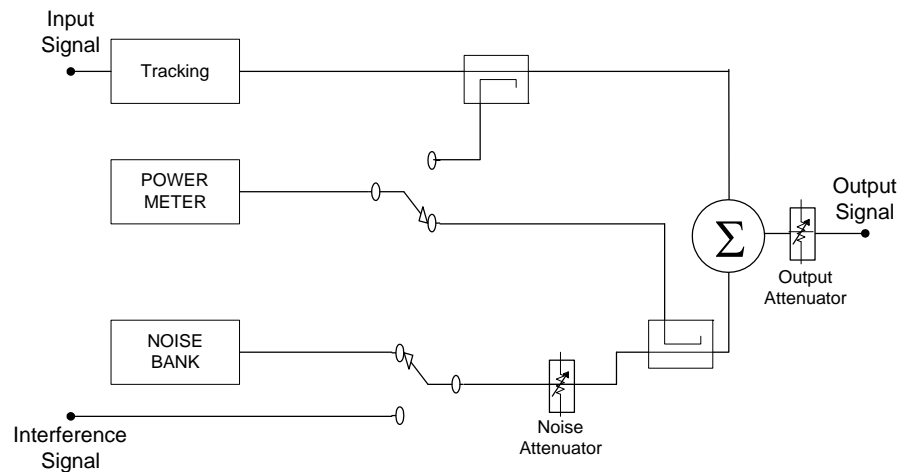

Figure 7. Simplified functional block diagram of one channel

Specifications

Mode Settings	C/N, C/No, Eb/No, C/I noise on/off, signal on/off, tracking on/off
Displayed Parameters	ratio, bit rate, duty cycle, frequency, averaging rate, averaging factor, output power, input power, delta input power
Signal Path Characteristics	
RF input power	
baseband	0 dBm to -50 dBm
tunable	0 dBm to -45 dBm (-50 dBm with degradation)
RF output power*	
baseband	0 dBm to -110 dBm
tunable	0 dBm to -105 dBm (-110 dBm with degradation)
Gain	0 to -60 dB*
Input duty cycle	1% to 100%
Nominal gain	0 dB (@attenuation = 0 dB)
Gain resolution	1 dB
Gain flatness	
baseband	< +/- 0.2 dB per 40MHz
tunable	< +/- 0.4 dB per 40MHz
Internal Spurious	
baseband	none
tunable	< - 105 dBm
Group delay	
baseband	+/- 0.20 ns per 40 MHz
tunable	+/- 6 ns per 40 MHz
Tracking range	+/- 5 dB minimum
Channel-to-	
Channel isolation	> 100 dB
Residual output noise	
baseband	< -149 dBm/Hz
tunable	< -145 dBm/Hz
Impedance	50 ohms
VSWR	1.2:1 maximum into 50 ohms
Connectors	Type N female
Noise Output Characteristics	
Power	0 dBm max. over approx. 200 MHz bandwidth
Flatness	
baseband	< +/- 0.2 dB per 40 MHz
tunable	< +/- 0.4 dB per 40 MHz
Amplitude resolution	0.015625 dB

Crest factor	18 dB minimum
--------------	---------------

Measurement	
C/N ratio accuracy	+/- 0.2 dB RSS
Averaging factor	10 to 9999
Averaging rate	5 to 999 Hz
Power meter accuracy	
baseband	+/- 0.2 dB max
tunable	+/- 0.5 dB max

Control and interface	
Local interface	Front panel keypad & display
Remote interface	IEEE-488.2 compatible
Save/Recall	10 states
Primary power	
Voltage	90-264 VAC autoranging
Frequency	48-66 Hz
Consumption	100 VA, maximum
Fuse	2A, slow-blow
Environmental Conditions	
Ambient operating temp	0° to 35° C
Dimensions	17" W x 5.25" H x 21" D

** with output attenuator installed.*

Figure 8. CNG Specifications

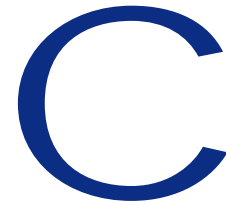

Maintenance and Warranty Section

Maintenance and Warranty

This section describes the CNG maintenance procedures and warranty information.



- Maintenance Information.
- Warranty Information.

Maintenance Information

Adjustments and Calibration

To maintain optimum measurement performance, the CNG should be calibrated every year. It is recommended that the CNG be returned to  or to an authorized calibration facility. For more information please contact our Customer Service Department at (201) 677-0008

Repair

The CNG should only be serviced by  service personnel or trained customer maintenance personnel using the  Service Manual for the CNG.



For instruments requiring service, either in or out of warranty, contact  Customer Service Department at (201) 677-0008 for pricing and instructions before returning your instrument. When you call, be sure to have the following information available:

- Model number.
- Serial number.
- Full description of the failure condition.

Note: Model and serial number can be found on the rear of the CNG unit, next to the the AC outlet.

Equipment Returns

All instruments returned to  for repair must be shipped prepaid. Instruments that are eligible for in-warranty repair will be returned prepaid to the customer. For all other situations the customer is responsible for all shipping charges. An evaluation fee may be charged for processing units that are found to have no functional or performance defects.

For out of warranty instruments,  will provide an estimate for the cost of repair. Customer approval of the charges will be required before repairs can be made. For units deemed to be beyond repair, or in situations which the customer declines to authorize repair, an evaluation charge may be assessed by .

Warranty Information

All **dBm** products are warranted against defects in material and workmanship for a period of one year from the date of shipment.

dBm will, at its option, repair or replace products that prove to be defective during the warranty period, provided they are returned to **dBm** and provided the preventative maintenance procedures are followed. Repairs necessitated by misuse of the product are not covered by this warranty. No other warranties are expressed or implied, including but not limited to implied warranties of merchantability and fitness for a particular purpose.

dBm is not liable for consequential damages. Please refer to the previous section for contact information and procedures to return the instrument to **dBm**.